



CATALOGUE

2026

Traffic Safety & Site Equipment

Designed for professional importers



 <https://sinoconcept.com>

 contact@sinoconcept.com



 Contact with Félix

 Follow Sino Concept

A WORD FROM THE FOUNDER

I founded Sino Concept with a clear objective:
to offer **factory-direct pricing**, **European quality standards**,
and **clear product specifications**.

I have been living and working in China since **2008**, which allows direct,
daily involvement with factories, production, and quality control.
Decisions are made on site, with no unnecessary intermediaries.

Our goal is simple:
you focus on sales and distribution, we take care of design,
production, and logistics.

Thank you for working with Sino Concept!

Félix Bizouard
Founder & Managing Director

WHO WE ARE



Founded in 2009, we design and supply traffic safety and urban equipment.



In-house product design.



Long-term manufacturing partners in China.



Operations based in Qingdao, China.



Head office registered in Hong Kong.

WHY OUR CUSTOMERS WORK WITH US



Factory-Direct
Pricing



European
Standards



REACH
Compliant Materials



Products Designed
By Our Team,
Not Copied



Same QUALITY
From One Order
To The Next



ROAD & TRAFFIC SAFETY DEVICES

SPEED CUSHIONS.....	05
LANE SEPARATORS.....	06
DELINEATOR POST.....	06
REFLECTIVE ROAD STUDS.....	07



CAR PARK SAFETY MANAGEMENT

SPEED BUMPS.....	09
ONE-PART SPEED BUMP.....	10
SPEED HUMPS.....	11
WHEEL STOPS.....	12
VEHICLE-SPECIFIC WHEEL STOPS.....	14
FLOOR BIKE RACK SERIES.....	15
FOLDING PARKING BARRIERS.....	17
WALK BEHIND SALT SPREADER.....	17



TRAFFIC CONTROL EQUIPMENT

TRAFFIC CONES.....	19
METAL ROADWORKS BEACON.....	21
PLASTIC ROADWORKS BEACON.....	21
SCANDINAVIAN DELINEATOR PANEL.....	22
PVC SANDBAG.....	22
EXPANDABLE METAL BARRIER.....	23
MANHOLE SAFETY BARRIER.....	23

CONTENTS

Durable & Reliable



EVENT MANAGEMENT

CABLE RAMPS.....	25
DDA WHEELCHAIR CABLE RAMPS.....	27
MODULAR CABLE RAMPS.....	28
HOSE PROTECTOR RAMPS.....	29
FLOOR CABLE COVERS.....	29
DROP OVER CABLE COVER.....	30
CROWD CONTROL BARRIERS.....	30
CROWD BARRIER STILLAGE.....	31
GRIDWALL MESH PANEL.....	31



STREET FURNITURE

BALL-TOP BOLLARDS.....	33
REMOVABLE BOLLARD SOCKET.....	34
PEDESTRIAN GUARDRAIL.....	35
DECORATIVE OUTDOOR TRASH BINS.....	37
STREET BENCH.....	37
HOOPED PERIMETER BARRIERS.....	38
LAMP POST PROTECTOR HOOPS.....	38
POLE AND COLUMN PROTECTORS.....	38

Road & Traffic Safety Devices

SPEED CUSHIONS.....	05
LANE SEPARATORS.....	06
DELINEATOR POST.....	06
REFLECTIVE ROAD STUDS.....	07



SPEED CUSHIONS



Durable and Eco-friendly: Speed cushions made from premium recycled material, a mix of plastic and rubber, REACH compliant, UV-resistant, and weatherproof. Provides long-lasting protection, ideal for mid-sized parking areas.



ACCESSORIES:



Aluminium H-Connectors



M12 Coach Screws, PE Plastic Anchors



PE Plastic Caps

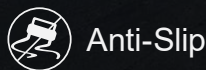

Anti-Slip



UV-Resistant



Heavy-Duty



SKID-PROOF SURFACE

Non-slip surface for better grip.



AVAILABLE IN BLACK

Other colours on request.



REFLECTIVE FILMS

Embedded thick thermoplastic reflective road marking films to enhance visibility and safety.



COMPANY NAME OR LOGO

Can be moulded-in for easy identification.



HEAVY-DUTY HARDWARE

Premium-quality screws and plastic anchors – rust-proof and highly durable.



CUSTOM-MADE PACKING

Designed for international shipping, easy storage and delivery.

TYPE	DIMENSIONS (L*W*H)	WEIGHT
4 Parts (2 right corners + 2 left corners)	2000 x 1800 x 65 mm (6.56' x 5.9' x 2.56'')	160 kg
6 Parts (2 right corners + 2 left corners + 2 middle parts)	3000 x 1800 x 65 mm (9.84' x 5.9' x 2.56'')	250 kg

LANE SEPARATORS



ACCESSORIES:



M12 Coach Screws, PE Plastic Anchors



PE Plastic Caps



PLASTIC-RUBBER COMPOSITE

Cost-effective, UV-resistant, and very sturdy.



REFLECTIVE FILMS

Embedded thick thermoplastic reflective road marking films to enhance visibility and safety.



360° SOLID GLASS ROAD STUD (PREMIUM VERSION)

Increases visibility and safety at night.



AVAILABLE IN BLACK

Other colours on request.

TYPE	DIMENSIONS (L*W*H)	GLASS ROAD STUDS	WEIGHT
Without road stud	1000 x 130 x 50 mm (39.4" x 5" x 2")	/	5 kg
With road stud	1000 x 130 x 50 mm (39.4" x 5" x 2")	Ø 50 mm (Ø1.97")	5.5 kg

DELINEATOR POST



Custom colours available: Customise



FLEXIBLE AND RESISTANT

Blow-moulded LDPE resists damage and returns to its original shape after impact, ensuring long-lasting durability.



EASY INSTALLATION

The built-in steel base and M12 screw make installation simple and secure.



HIGHLY REFLECTIVE FILMS

Engineering-Grade (RA1)
High-Intensity Prismatic Grade (RA3)



CONVENIENT HANDLES

Two handles for easy carrying and installation.

TYPE	DIMENSIONS (D*H)
Delineator post	Ø 200 mm x 750 mm

GLASS ROAD STUDS



TEMPERED GLASS CONSTRUCTION

Durable, long-lasting, with excellent performance after installation.



AVAILABLE IN VARIOUS COLOURS

Different colours to improve visibility in various environments.



360° VISIBILITY

Optimal visibility in low light conditions.

TYPE

Glass road stud - Small

DIMENSIONS (D*H)

Ø 50 x 55 mm (2" x 2.2")

Glass road stud - Large

Ø 100 x 50 mm (4" x 2")

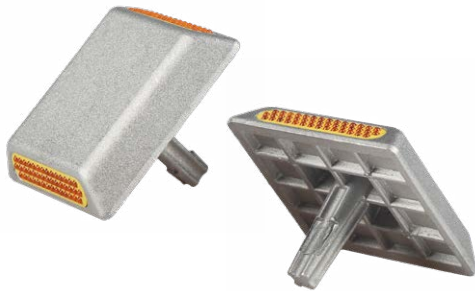

ALUMINIUM ROAD STUDS

TYPE	DIMENSIONS (L*W*H)	MAX. LOAD
Heavy-duty	100 x 100 x 75 mm (4" x 4" x 3")	20 to 30 tons
Standard	100 x 100 x 75 mm (4" x 4" x 3")	10 tons

PLASTIC ROAD STUDS

DIMENSIONS (L*W*H)	MAX. LOAD
100 x 100 x 20 mm (4" x 4" x 0.8")	5 to 10 tons



RUBBER-BASED ROAD STUDS

DIMENSIONS (H*W*T)

145 x 86 x 70 mm (5.7" x 3.4" x 2.75")



STEEL-BASED ROAD STUDS

TYPE	DIMENSIONS (L*W*H)
One side	110 x 50 x 70 mm (4.3" x 2" x 2.8")
Two sides	120 x 50 x 70 mm (4.7" x 2" x 2.8")

Car Park Safety Management

SPEED BUMPS	09
ONE-PART SPEED BUMP	10
SPEED HUMPS	11
WHEEL STOPS	12
VEHICLE-SPECIFIC WHEEL STOPS	14
FLOOR BIKE RACK SERIES	15
FOLDING PARKING BARRIERS	17
WALK BEHIND SALT SPREADER	17



SPEED BUMPS

1. Standard Version:

Suitable for light vehicles and light utility vehicles under normal usage conditions. Maximum Load Capacity: 20 tons per axle.

2. Heavy-duty Version:

Suitable for light utility vehicles, with enhanced durability. Maximum Load Capacity: 25 tons per axle.



STANDARD VERSION



6 kg 9 kg
50 mm 70 mm



UNDERSIDE DESIGN
No built-in cable channels.

HEAVY-DUTY VERSION



7 kg 12 kg
50 mm 70 mm



UNDERSIDE DESIGN
Built-in cable channels.

PARTS & ACCESSORIES



End Caps



Yellow Middle Parts



Black Middle Parts



M12 Coach Screws, PE Plastic Anchors

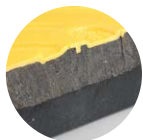

YELLOW MOULDED-IN COVER
Built into the speed bump to stay bright with no peeling or fading. Yellow stays yellow.

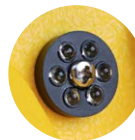

180° GLASS BEAD REFLECTORS
Highly visible in all conditions.

HEIGHT	PART	DIMENSIONS (L*W*H)	MAX. CABLE DIAMETER	WEIGHT (STANDARD / HEAVY-DUTY)
50 mm	Middle part	500 x 350 x 50 mm (20" x 14" x 2")	Ø 30 mm (Ø 1.18")	6 kg / 7 kg
50 mm	End cap	250 x 350 x 50 mm (10" x 14" x 2")	Ø 30 mm (Ø 1.18")	2 kg / 2.5 kg
70 mm	Middle part	500 x 400 x 70 mm (20" x 16" x 2.76")	Ø 35 mm (Ø 1.38")	9 kg / 12 kg
70 mm	End cap	250 x 400 x 70 mm (10" x 16" x 2.76")	Ø 35 mm (Ø 1.38")	3.5 kg / 4.5 kg

ONE-PART SPEED BUMP



Material: It is made from a heavy-duty Plastic-Rubber composite, which makes it long-lasting. It works well in all weather conditions and on different road surfaces like asphalt, concrete, or block paving.

PARTS / ACCESSORIES:



End Caps



Middle Part



M12 Coach Screws, PE Plastic Anchors



TYPE	DIMENSIONS (L*W*H)	MAX. CABLE DIAMETER	WEIGHT
Middle part	1830 x 300 x 50 mm (6' x 12" x 2")	Ø 30 mm (Ø 1.18")	20.5 kg
End cap	150 x 300 x 50 mm (6" x 12" x 2")	/	1.5 kg



SKID-PROOF SURFACE:

Moulded anti-slip texture for better grip as standard. (Factory-applied reflective film available instead for improved visibility.)



INTERLOCKING SYSTEM

Easy to install and use, with no risk of disconnecting during operation.



2-IN-1 PRODUCT

Built-in channels for cable protection.

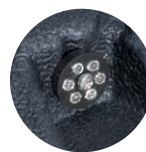

180° GLASS BEAD REFLECTORS

Highly visible in all conditions.

■ SPEED HUMPS

Material: Made from robust plastic-rubber composite material, it performs exceptionally well under heavy trucks, cars, and pedestrian usage. Its modular construction ensures suitability for roads of various lengths, providing a neat and professional installation.

Skid-Proof surface: Moulded anti-slip texture for better grip as standard. (Factory-applied reflective film available instead for improved visibility.)



✂ PARTS / ACCESSORIES:



End Caps

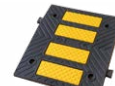

Middle Parts



M12 Coach Screws, PE Plastic Anchors

HEIGHT	MIDDLE PART DIMENSIONS (L*W*H)	END CAP DIMENSIONS (L*W*H)	MAX. CABLE DIAMETER	WEIGHT (END CAP / MIDDLE PART)
30 mm (1.2")	500 x 600 x 30 mm (20" x 24" x 1.18")	250 x 600 x 30 mm (10" x 24" x 1.18")	/	3 kg / 8 kg
50 mm (2")	500 x 600 x 50 mm (20" x 24" x 1.97")	250 x 600 x 50 mm (10" x 24" x 1.97")	2 x Ø 30 mm (Ø 1.18")	4.5 kg / 11 kg
50 mm (2")	500 x 900 x 50 mm (20" x 35" x 1.97")	250 x 900 x 50 mm (10" x 35" x 1.97")	2 x Ø 30 mm (Ø 1.18")	7 kg / 16 kg
70 mm (3")	500 x 900 x 70 mm (20" x 35" x 2.76")	250 x 900 x 70 mm (10" x 35" x 2.76")	2 x Ø 45 mm (Ø 1.77")	7.5 kg / 21 kg
70 mm (3")	500 x 1200 x 70 mm (20" x 47" x 2.76")	250 x 1200 x 70 mm (10" x 47" x 2.76")	2 x Ø 45 mm (Ø 1.77")	9.5 kg / 28 kg



3 CM SPEED HUMP
(600 mm wide)



5 CM SPEED HUMP
(600 mm wide)



5 CM SPEED HUMP
(900 mm wide)



7 CM SPEED HUMP
(900 mm wide)



7 CM SPEED HUMP
(1200 mm wide)

WHEEL STOPS



Durable and Eco-friendly: Car Park Wheel Stop made from premium recycled material, a mix of plastic and rubber, REACH compliant, UV-resistant, weatherproof, and free from unpleasant odours, ensuring long-lasting protection and reducing costs.

ACCESSORIES:



M12 Coach Screws, PE Plastic Anchors



PP Plastic Caps

TYPE	DIMENSIONS (L*W*H)	REFLECTIVE FILM COLOURS	WEIGHT
550 mm (2')	550 x 150 x 100 mm (2' x 6" x 4")	Yellow, white	4.5 kg
900 mm (3')	900 x 150 x 100 mm (3' x 6" x 4")	Yellow, white	7 kg
1220 mm (4')	1220 x 150 x 100 mm (4' x 6" x 4")	Yellow, white	9 kg
1650 mm (5.4')	1650 x 150 x 100 mm (5.4' x 6" x 4")	Yellow, white	11.5 kg
1830 mm (6')	1830 x 150 x 100 mm (6' x 6" x 4")	Yellow, white	13.5 kg

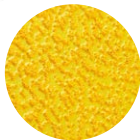

REFLECTIVE FILMS

Embedded thick thermoplastic reflective road marking films to enhance visibility and safety.

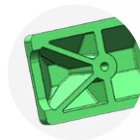

HEAVY-DUTY STRUCTURE

Thick walls and V-shaped ribs for maximum strength in tough conditions.



CONVENIENT STORAGE

Screws, anchors, and caps stored underneath for easy setup.

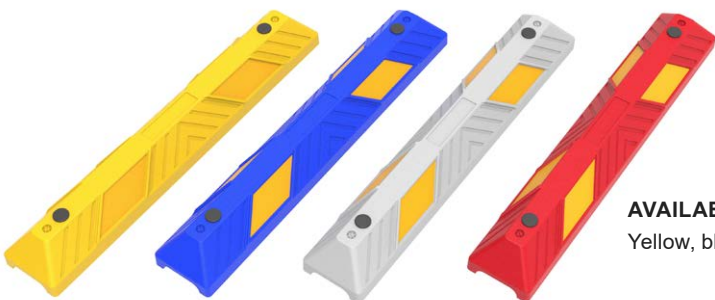

AVAILABLE IN MORE COLOURS

Yellow, blue, white, red, etc.



VEHICLE-SPECIFIC WHEEL STOPS

Material: Plastic-Rubber composite.

Car Wheel Stop: Suitable for standard car parking spaces.

Coach Wheel Stop: Built for coaches and passenger transport vehicles in dedicated parking areas.

HGV Wheel Stop: Built for HGVs and other heavy vehicles in industrial zones.

ACCESSORIES:



M12 Coach
Screws, PE Plas-
tic Anchors

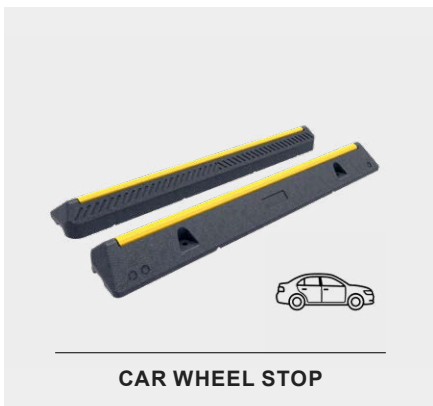

INTEGRATED HIGH-VISIBILITY MARKING

Mould-in yellow marking for enhanced visibility and safety.

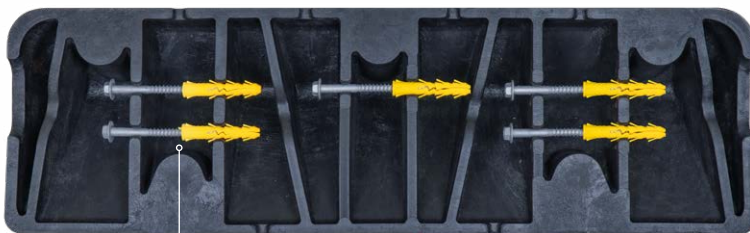

CONVENIENT STORAGE

Screws and anchors stored underneath for easy setup.



CONVENIENT HANDLES

Easy to carry and to install.

TYPE	DIMENSIONS (L*W*H)	WEIGHT
Car Wheel Stop	1000 x 140 x 80 mm (39.4" x 5.5" x 3.1")	6 kg
Coach Wheel Stop	1000 x 220 x 115 mm (39.4" x 8.7" x 4.5")	14 kg
HGV Wheel Stop	1000 x 300 x 150 mm (39.4" x 11.8" x 5.9")	21 kg

FLOOR BIKE RACK SERIES



FULLY HOT-DIPPED GALVANISED (MINIMUM 80 MICRONS)

Highly corrosion-resistant treatment that prevents rust.



SPACE-SAVING

Low and high hoops save space for bike parking.



LOCKABLE OPTIONS

Securely lock bike frames for extra safety.



CUSTOM-MADE PACKING

Designed for international shipping, easy storage and delivery.

ACCESSORIES:



Ground Spike



Flange Locknuts



90° Angle

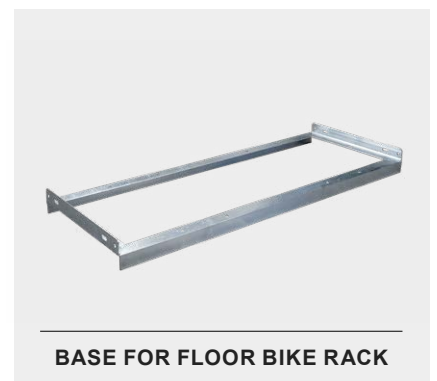
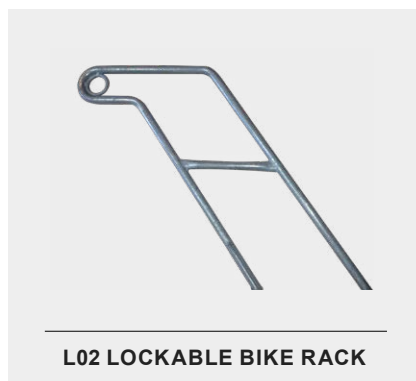
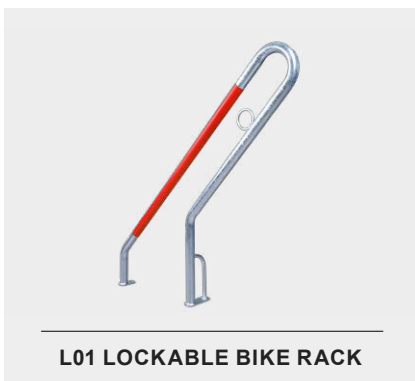

TYPE	TUBE DIAMETER	MAX. TYRE WIDTH	WEIGHT(SMALL / BIG)
S01, S02, S03	Ø 18 mm (Ø 0.7")	45 mm (1.8")	1.2 kg / 1.4 kg, 1.6 kg / 1.8 kg, 1 kg / 1.1 kg

TYPE	AVAILABLE LENGTHS	WIDTH	WEIGHT(700 MM / 1050 MM)
BASE	700 mm (27.6"), 1000 mm (39.4"), 1050 mm (41.3"), 1100 mm (43.3"), etc	395 mm (15.6")	3.5 kg / 4.5 kg



FOLDING PARKING BARRIERS



STANDARD

Material: Mild steel tube.

Surface Treatment:

Options 1: Electro-galvanised.
 Options 2: Fully hot-dipped galvanised (after welding).



HEAVY DUTY

Material: Mild steel tube.

Surface Treatment:

Options 1: Electro-galvanised.
 Options 2: Fully hot-dipped galvanised (after welding).

TYPE	WIDTH	HEIGHT	WEIGHT
Standard	700 mm (27.6")	430 mm (16.9")	3 kg
Heavy duty	880 mm (34.6")	440 mm (17.3")	10 kg

WALK BEHIND SALT SPREADER



Hopper colour:
 Customisable

25 L

Hopper Material: Polypropylene (PP).

Frame Material: Steel tubing and powder-coated anti-corrosion finish.

Bolts, Rods and Linkages: Steel and electro-galvanised.

Spreader Gear: Nylon.



Hopper colour:
 Customisable

45 L

Hopper Material: Polypropylene (PP).

Frame Material: Steel tubing and powder-coated anti-corrosion finish.

Spreader Gear, Bolts, Rods and Linkages: 304 stainless steel.

TYPE	DIMENSIONS (L*W*H)	SPREADING WIDTH	WEIGHT
25 L	1120 mm × 560 mm × 850 mm (44.1" × 22.0" × 33.5")	3000 mm (118.1")	12 kg
45 L	1110 mm × 670 mm × 835 mm (43.7" × 26.4" × 32.9")	4000 mm (157.5")	17.5 kg

Traffic Control Equipment

TRAFFIC CONES	19
METAL ROADWORKS BEACON	21
PLASTIC ROADWORKS BEACON	21
SCANDINAVIAN DELINEATOR PANEL	22
PVC SANDBAG	22
EXPANDABLE METAL BARRIER.....	23
MANHOLE SAFETY BARRIER.....	23





TRAFFIC CONES



MAXI GRIP HANDLE

Handle with groove and textured grip for easy, efficient use, even with gloves.



FILM PROTECTION

Reflective films are embedded with a 1 mm recess to prevent tearing.



UNIQUE STACKING SYSTEM

Cone trunks stack apart, preventing sticking and protecting reflective films.

TYPE	HEIGHT	BASE DIMENSIONS	REFLECTIVE SHEETING HEIGHT	WEIGHT
300 mm	300 mm (11.8")	215 x 215 mm (8.5" x 8.5")	100 mm (3.9") × 1	0.5 kg
500 mm	500 mm (19.7")	275 x 275 mm (10.8" x 10.8")	100 mm (3.9") × 2	1.1 kg
500 mm (weighted)	500 mm (19.7")	275 x 275 mm (10.8" x 10.8")	100 mm (3.9") × 2	1.8 kg
750 mm	750 mm (29.5")	350 x 350 mm (13.8" x 13.8")	150 mm (5.9") × 2	2 kg
750 mm (weighted 1)	750 mm (29.5")	350 x 350 mm (13.8" x 13.8")	150 mm (5.9") × 2	3.2 kg
750 mm (weighted 2)	750 mm (29.5")	365 x 365 mm (14.4" x 14.4")	150 mm (5.9") × 2	4.2 kg
750 mm (highway)	750 mm (29.5")	400 x 400 mm (15.7" x 15.7")	150 mm (5.9") × 2	4.2 kg

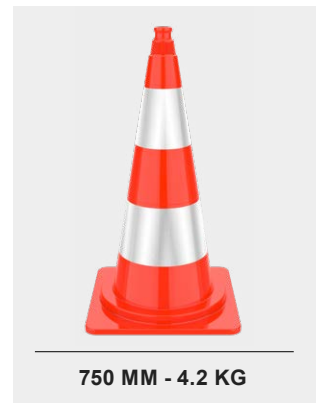
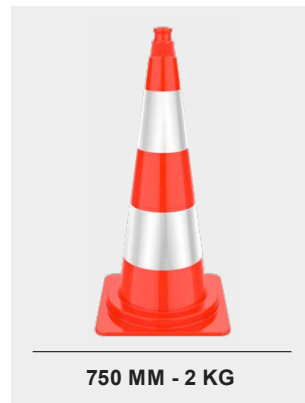





METAL ROADWORKS BEACON

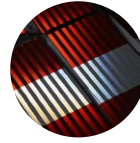

HIGHLY REFLECTIVE SHEETINGS
 Engineering-Grade (RA1)
 High-Intensity Prismatic Grade (RA3).



GALVANISED STEEL ANGLE & PLATE
 Ensures durability and corrosion resistance.



REINFORCED STEEL RIVETS
 Ensures optimal durability, even under intensive use.



ANGLED END
 Allows fast and easy installation, even on hard ground.

HEIGHT	GALVANISED STEEL ANGLE	GALVANISED STEEL PLATE	WEIGHT
1100 mm (43")	20 x 15 mm (0.78" x 0.59")	150 x 375 mm (5.9" x 14.7")	0.95 kg



PLASTIC ROADWORKS BEACON



CONVENIENT HANDLE
 Easy to carry and install.



HIGHLY REFLECTIVE SHEETINGS
 Engineering-Grade (RA1)
 High-Intensity Prismatic Grade (RA3).



DIRECTIONAL ARROW
 Helps you to position the beacon in the correct direction.



COMPANY NAME OR LOGO
 Can be moulded-in for easy identification.

MATERIAL	DIMENSIONS (H*W*T)	REFLECTIVE SHEETING DIMENSIONS	WEIGHT
Recycled high-density polyethylene (HDPE)	1300 x 280 x 60 mm (51" x 11" x 2.4")	1000 x 250 mm (39" x 10")	2.3 kg

SCANDINAVIAN DELINEATOR PANEL



HIGHLY REFLECTIVE SHEETINGS

Fluo Engineering-Grade (RA1)
Fluo High-Intensity Prismatic Grade (RA3).



DIRECTIONAL ARROW

Helps you to position the beacon in the correct direction.



CONVENIENT HANDLE

Easy to carry and install.



SPACE-SAVING STORAGE

Stackable design saves space, prevents slipping, and keeps panels organised.

MATERIAL	DIMENSIONS (H*W*T)	REFLECTIVE SHEETING DIMENSIONS	WEIGHT
Polypropylene (PP)	1000 x 225 x 22 mm (39.5" x 8.85" x 0.87")	800 x 190 mm (31.5" x 7.5")	1 kg

PVC SANDBAG

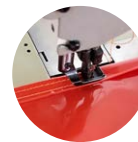

DOUBLE-STITCHED SEAMS

Strong stitching for long-lasting use.



HEAVY-DUTY ROPE

Easy to carry and handle.



8 ALUMINIUM EYELETS

Corrosion-resistant aluminium for a longer lifespan.



COMPANY NAME OR LOGO

Screen-printed logo for easy identification.

MATERIAL	DIMENSIONS (L*W)	DENSITY	CAPACITY	WEIGHT
PVC-coated fabric	600 x 400 mm (24" x 15")	640 g/m ²	15 kg (33 lbs) – delivered empty	0.35 kg

EXPANDABLE METAL BARRIER



 PACKAGE:



SEAMLESS, STRONG WELD

Strong welding to prevent cracks.



REINFORCED STEEL RIVETS

Ensures optimal durability, even under intensive use.



INTERLOCKING SYSTEM

For easy transportation and storage.



ANTI-SLIP FEET

Improves stability and ensures safety when installed.

HEIGHT	LENGTH	FINISHING TREATMENT	WEIGHT
1000 mm (39")	Folded: 200 mm (8"), Unfolded: 2.85 m (9')	Anti-UV powder coating	8.5 kg

MANHOLE SAFETY BARRIER

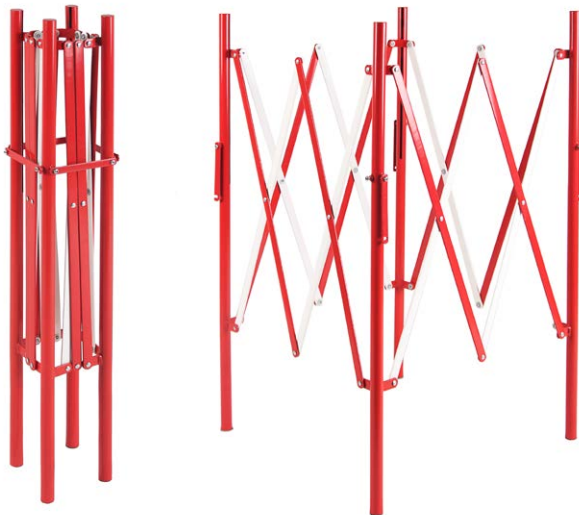

 PACKAGE:



SEAMLESS, STRONG WELD

Strong welding to prevent cracks.



REINFORCED STEEL RIVETS

Ensures optimal durability, even under intensive use.



INTERLOCKING SYSTEM

For easy transportation and storage.



ANTI-SLIP FEET

Improves stability and ensures safety when installed.

HEIGHT	LENGTH & WIDTH	FINISHING TREATMENT	WEIGHT
1000 mm (39")	Folded: 150 x 150 mm (6" x 6"), Unfolded: 1.5 x 1.5 m (4.9' x 4.9')	Anti-UV powder coating	11 kg

Event Management

CABLE RAMPS	25
DDA WHEELCHAIR CABLE RAMPS	27
MODULAR CABLE RAMPS	28
HOSE PROTECTOR RAMPS	29
FLOOR CABLE COVERS	29
DROP OVER CABLE COVER	30
CROWD CONTROL BARRIERS	30
CROWD BARRIER STILLAGE	31
GRIDWALL MESH PANEL	31



CABLE RAMPS

Base Material:

- 1. Standard Version:** Plastic-Rubber composite as a more economical option.
- 2. Heavy-duty Version:** Vulcanised rubber for flexibility and durability.

Both are REACH compliant, odourless, and built to last.



STANDARD VERSION



Plastic-Rubber Composite

HEAVY-DUTY VERSION



Vulcanised Rubber

CORNER SECTIONS & WHEELCHAIR CABLE RAMPS



2-Channel



3-Channel



5-Channel

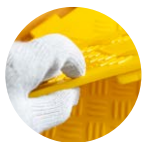

THICK YELLOW LID
UV-stabilised PE with a non-slip surface to reduce tripping risks.



INTERLOCKING SYSTEM
Easy to install and use, with no risk of disconnecting during operation.



REINFORCED STRUCTURE
Premium material to reinforce key stress points like hinges and connectors.



45° LEFT TURN / RIGHT TURN (2, 3 AND 5 CHANNELS)
Helps create right or left turns, keeping walking spaces safe.

TYPE	DIMENSIONS (L*W*H)	CHANNEL DIMENSIONS (W*H)	WEIGHT (STANDARD / HEAVY-DUTY)
2-Channel	990 x 240 x 45 mm (39" x 9.5" x 1.8")	30 x 32 mm (1.18" x 1.26")	6 kg / 7 kg
3-Channel	900 x 500 x 70 mm (35.5" x 20" x 2.75")	65 x 50 mm (2.56" x 1.97") x 2, 56 x 50 mm (2.2" x 1.97")	16 kg / 18 kg
5-Channel	900 x 500 x 50 mm (35.5" x 20" x 2")	38 x 32 mm (1.5" x 1.26")	13 kg / 14 kg

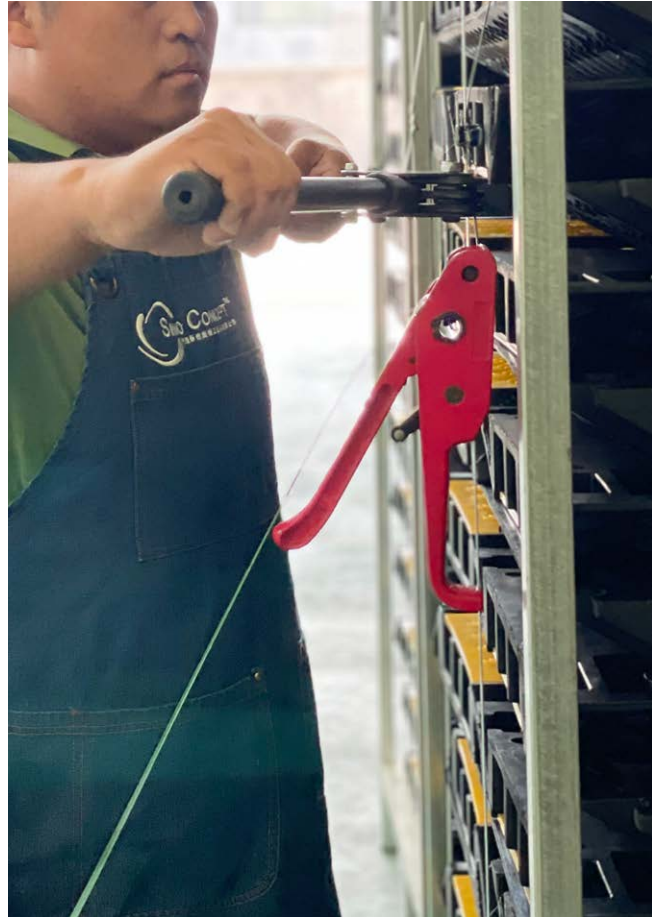

DDA WHEELCHAIR CABLE RAMPS



Material:

- 1. Base & Ramps:** Vulcanised rubber for flexibility and durability.
- 2. Cover:** UV-resistant polyethylene cover to endure extreme weather conditions and sunlight exposure.

REACH compliant, odourless, and built to last.

COMPATIBLE PRODUCT :



2-Channel Cable Ramp

3-Channel Cable Ramp

5-Channel Cable Ramp



2-CHANNEL



3-CHANNEL



5-CHANNEL



BUILT-IN HANDLE

Easy to transport and reduces fatigue, saving time during installation and storage.



INTERLOCKING SYSTEM

Easy to install and use, with no risk of disconnecting during operation.



NYLON ROD

Integrated nylon rod securely connects the base and yellow cover, preventing detachment.



DDA/ADA COMPLIANT

Meets the requirements of the DDA and ADA standards, ensuring accessibility.

TYPE	DIMENSIONS (L*W*H)	CHANNEL DIMENSIONS (W*H)	WEIGHT
2-Channel	490 x 785 x 45 mm (19.3" x 30.9" x 1.8")	30 x 32 mm (1.18" x 1.26")	11.5 kg
3-Channel	450 x 1380 x 70 mm (17.7" x 54.3" x 2.8")	65 x 50 mm (2.56" x 1.97") x 2, 56 x 50 mm (2.2" x 1.97")	23 kg
5-Channel	450 x 1090 x 50 mm (17.7" x 42.9" x 2")	38 x 32 mm (1.5" x 1.26")	16 kg

MODULAR CABLE RAMPS



Material:

- 1. Base & Ramps:** Vulcanised rubber for flexibility and durability.
- 2. Cover:** UV-resistant polyethylene cover to endure extreme weather conditions and sunlight exposure.

REACH compliant, odourless, and built to last.

THE RAMPS FOR MIDDLE SECTION



Standard Ramp



Gentle Slope Ramp



Half Gentle Slope Ramp

TYPE	DIMENSIONS (L*W*H , EXCLUDING CONNECTORS)	CHANNEL DIMENSIONS (W*H)	WEIGHT
Middle section	895 x 370 x 50 mm (35.2" x 14.6" x 2")	37.5 x 35 mm (1.48" x 1.38")	13 kg
Standard ramp	895 x 140 x 50 mm (35.2" x 5.5" x 2")	/	5 kg
Gentle slope ramp	895 x 500 x 50 mm (35.2" x 19.7" x 2")	/	16 kg
Half gentle slope ramp	447.5 x 500 x 50 mm (17.6" x 19.7" x 2")	/	9 kg



INTERLOCKING SYSTEM

Easy to install and use, with no risk of disconnecting during operation.

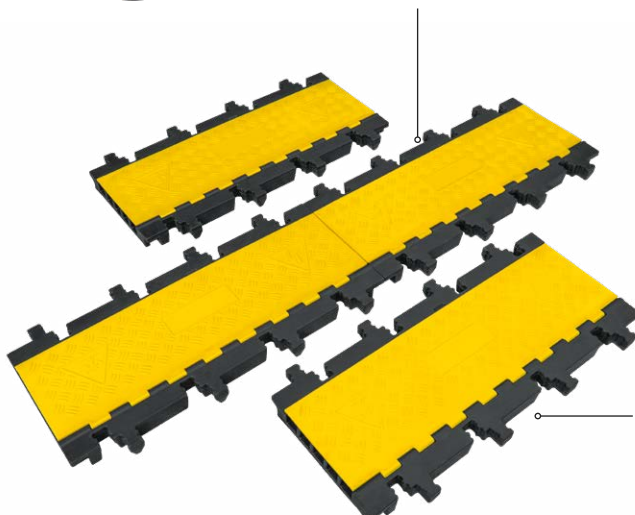

SKID-PROOF SURFACE

Non-slip surface for better grip.



GENTLE SLOPE RAMP

5° incline for smooth and easy access for wheel-chairs and pedestrians.



FLEXIBLE MODULAR DESIGN

The modular cable ramp allows for easy and flexible assembly to suit various needs.

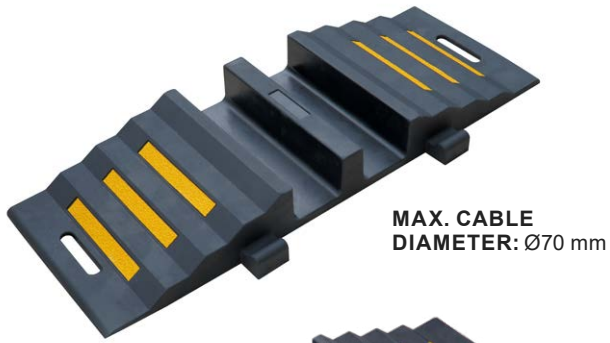

MAX. CABLE DIAMETER: Ø70 mm

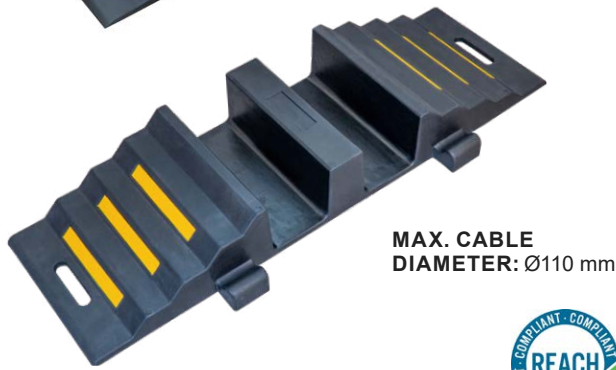

MAX. CABLE DIAMETER: Ø110 mm



HOSE PROTECTOR RAMPS



BUILT-IN HANDLE

Easy to transport and reduces fatigue, saving time during installation and storage.



REFLECTIVE FILMS

Embedded thermoplastic reflective road marking films to enhance visibility and safety.



INTERLOCKING SYSTEM

Easy to install and use, with no risk of disconnecting during operation.



CUSTOM-MADE PACKING

Designed for international shipping, easy storage and delivery.

DIMENSIONS (L*W*H)	CHANNEL DIMENSIONS (W*H)	MAX. WEIGHT CAPACITY	WEIGHT
850 x 300 x 85 mm (33" x 12" x 3.3")	90 x 70 mm (3.54" x 2.76")	9,000 kg (20,000 lbs) per axle	11.5 kg
970 x 300 x 130 mm (38" x 12" x 5")	110 x 110 mm (4.33" x 4.33")	20,000 kg (44,000 lbs) per axle	19 kg

FLOOR CABLE COVERS

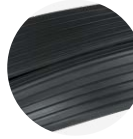

SKID-PROOF SURFACE

Non-slip surface for better grip.



1 CHANNEL - TOP SLIT

To install the cable from the top.



3 CHANNELS - TOP & BOTTOM SLIT

To install the cable from the top & bottom.



CUSTOM-MADE PACKING

Designed for international shipping, easy storage and delivery.

TYPE	DIMENSIONS	MAX. CABLE DIAMETER	WEIGHT
1-Channel	10,000 x 100 x 30 mm (33' x 4" x 1.2")	Ø 20 mm (Ø 0.8")	21 kg
3-Channel	4,000 x 160 x 50 mm (13' x 6" x 2")	1 x Ø 40 mm (Ø 1.6") and 2 x Ø 20 mm (Ø 0.8")	21 kg

■ DROP OVER CABLE COVER



OPTIONAL COLOURS:



SKID-PROOF SURFACE

Non-slip surface for better grip.



MADE OF THERMOPLASTIC POLYURETHANE

Flexible material that perfectly fits uneven floors.



INTERLOCKING SYSTEM

Easy to install and use, with no risk of disconnecting during operation.



ANTI-SLIP PADS

Improves grip on smooth surfaces.

TYPE	DIMENSIONS (L*W*H)	CHANNEL DIMENSIONS (W*H)	WEIGHT
Small	914 x 135 x 22 mm (36" x 5.25" x 0.87")	40 x 14 mm (1.57" x 0.55")	1.5 kg
Large	914 x 280 x 40 mm (36" x 11" x 1.57")	104 x 30 mm (4" x 1.25")	4 kg

■ CROWD CONTROL BARRIERS



SEAMLESS, STRONG WELD

Strong welding to prevent cracks.



FULLY HOT-DIPPED GALVANISED (MINIMUM 80 MICRONS)

Highly corrosion-resistant treatment that prevents rust.



PATENTED HANDLE

Allows carrying two barriers at once (unique on the market).



REINFORCED INTERLOCKING SYSTEM

Extra-thick 5 mm connectors for strong and stable use.

TYPE	DIMENSIONS (L*H)	TUBE DIAMETERS	WEIGHT
1-Metre Crowd Barrier	1000 x 1030 mm (39" x 40.5")	Frame: Ø 32 mm (Ø 1.3"), 6 Inner rails: Ø 16 mm (Ø 0.6")	6.5 kg
2-Metre Crowd Barrier	2000 x 1030 mm (79" x 40.5")	Frame: Ø 32 mm (Ø 1.3"), 14 Inner rails: Ø 16 mm (Ø 0.6")	10.5 kg

■ CROWD BARRIER STILLAGE

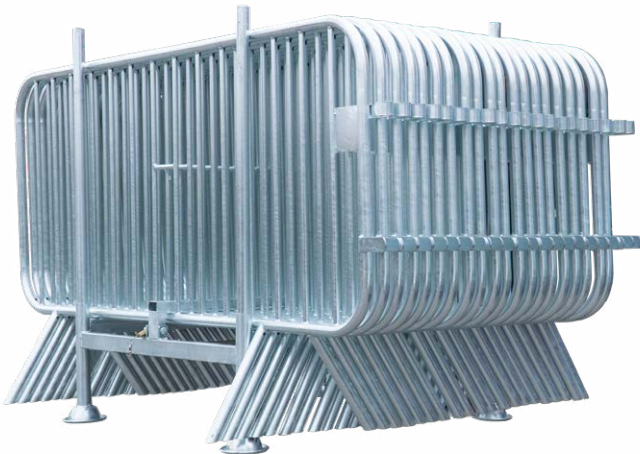

🔗 APPLICABLE PRODUCTS:



SEAMLESS, STRONG WELD
 Strong welding to prevent cracks.



FULLY HOT-DIPPED GALVANISED (MINIMUM 80 MICRONS)
 Highly corrosion-resistant treatment that prevents rust.



SINGLE LOCK SYSTEM
 Simple and effective, prevents the loss of crowd control barriers.



STACKING SYSTEM
 Stable stacking for easy management.

DIMENSIONS (L*W*H)	CONTAINS	WEIGHT
980 x 910 x 1200 mm (38.6" x 35.8" x 47.2")	20 Pieces of crowd barriers	32 kg

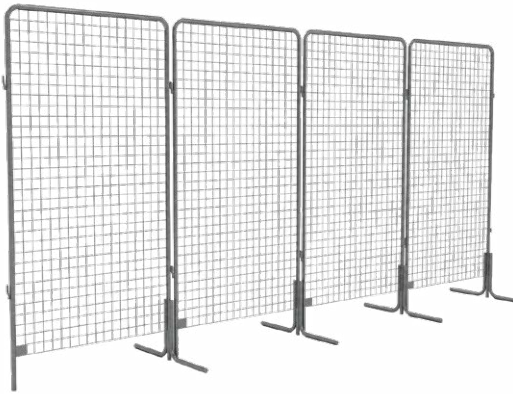

■ GRIDWALL MESH PANEL

Material
 Mild steel.

Finishing Treatment
 Grey hammered powder coating.

🔗 PACKAGE:



LENGTH	HEIGHT	TUBE DIAMETER	WEIGHT
1000 mm	2000 mm	Ø25 mm	9 kg



Street Furniture

BALL-TOP BOLLARDS.....	33
REMOVABLE BOLLARD SOCKET	34
PEDESTRIAN GUARDRAIL.....	35
DECORATIVE OUTDOOR TRASH BINS	37
STREET BENCH	37
HOOPED PERIMETER BARRIERS.....	38
LAMP POST PROTECTOR HOOPS.....	38
POLE AND COLUMN PROTECTORS	38



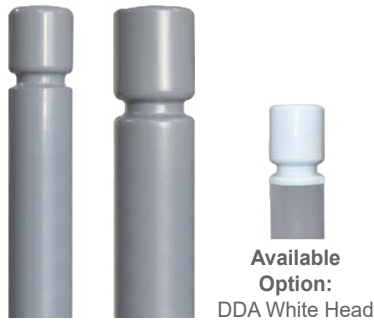
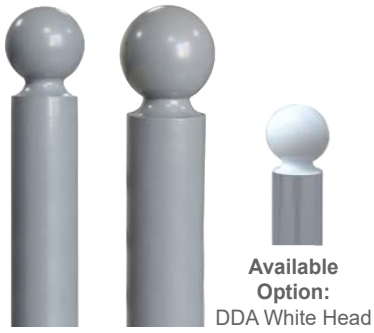

BALL-TOP BOLLARDS

GROOVE BOLLARDS

DECORATIVE BOLLARDS



All our metal products are available in various surface and finishing treatments:

- Zinc-rich primer powder.
- Fully hot-dipped galvanised (after welding).
- Anti-UV powder coating

TYPE	DIAMETER	HEIGHT
Ball-top bollard	Ø76 mm / 114 mm	1200 mm / 1500 mm
Groove bollard	Ø76 mm / 102 mm	1200 mm / 1500 mm
Decorative bollard	Ø60 mm	1200 mm / 1500 mm

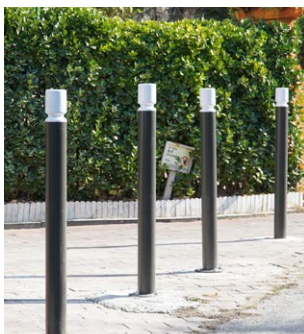



3-GROOVE BOLLARDS

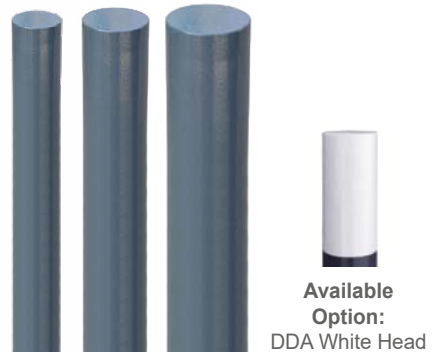

FLAT-TOP BOLLARDS

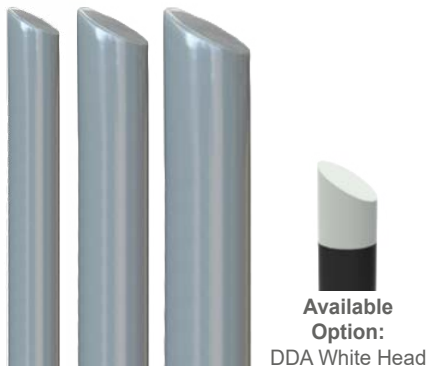

MITRE-TOP BOLLARDS



DOME-TOP BOLLARDS

TYPE	DIAMETER	HEIGHT	THICKNESS
3 Grooves bollard	Ø76 mm	1200 mm / 1500 mm	3 mm
Flat-top bollard	Ø76 mm / 88.9 mm / 102 mm	1200 mm / 1500 mm	3 mm
Mitre-top bollard	Ø76 mm / 88.9 mm / 102 mm	1200 mm / 1500 mm	3 mm
Dome-top bollard	Ø76 mm / 88.9 mm / 102 mm	1200 mm / 1500 mm	3 mm

REMOVABLE BOLLARD SOCKET

Material

Mild steel tube.

Surface Treatment

Fully hot-dipped galvanised (after welding).

Finishing Treatment

Anti-UV powder coating.



DIAMETER	HEIGHT
Ø76 mm / 88.9 mm / 102 mm	275 mm



CROSS PEDESTRIAN GUARDRAIL

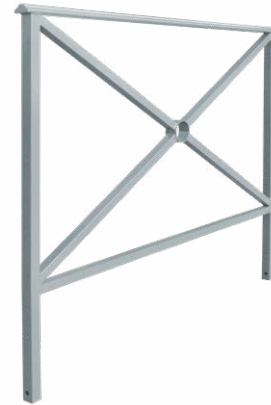

SHANGHAI PEDESTRIAN GUARDRAIL

TYPE	LENGTH	HEIGHT
Cross pedestrian guardrail	1640 mm / 840 mm	1100 mm
Shanghai pedestrian guardrail	1500 mm / 1000 mm	1250 mm



All our metal products are available in various surface and finishing treatments:

- Zinc-rich primer powder.
- Fully hot-dipped galvanised (after welding).
- Anti-UV powder coating



BALL-TOP PEDESTRIAN GUARDRAIL



DIAMOND PATTERN PEDESTRIAN GUARDRAIL

TYPE	LENGTH	HEIGHT
Ball-top pedestrian guardrail	1640 mm / 840 mm	1100 mm
Diamond pattern pedestrian guardrail	1640 mm / 840 mm	1100 mm



DECORATIVE OUTDOOR TRASH BINS



Material

Mild steel tube.

Surface Treatment

Options 1: Zinc-rich primer powder.

Options 2: Fully hot-dipped galvanised (after welding).

Available Finishing Treatment

Anti-UV powder coating.



TYPE	DIAMETER	HEIGHT	CAPACITY
Trash can	Ø350 mm / 445 mm	780 mm / 860 mm	50 L / 80 L

STREET BENCH



Cast Iron Legs

Material:

Durable steel.

Available Finishing Treatment:

Anti-UV Powder Coating.

Wood Slats

Material:

Pine wood.

Protective Finish:

Wood coating and clear varnish.

ACCESSORIES :



Open-Ended Spanner



Hex Key



Bolt Fixing Kit

TYPE	LENGTH	HEIGHT	SEAT HEIGHT	WIDTH	WEIGHT
Street bench	1800 mm	745 mm	440 mm	580 mm	36.2 kg

HOOPED PERIMETER BARRIERS



Material

Mild steel tube.

Surface Treatment

Fully hot-dipped galvanised (after welding).

Available Finishing Treatment

Anti-UV powder coating.

Customise your hoop barriers

with optional features:



CROSSBAR

Improves rigidity and visibility.



BASE PLATE

For surface mounting and easier installation.

TYPE	LENGTH	HEIGHT
Surface mounted	1000, 1500, 2000 mm	1000 mm
Embedded	1000, 1500, 2000 mm	1300 mm



LAMP POST PROTECTOR HOOPS

Material

Mild steel tube.

Surface Treatment

Fully hot-dipped galvanised (after welding).

Available Finishing Treatment

Anti-UV powder coating.

TYPE	HEIGHT	WIDTH	THICKNESS
Surface mounted	690 mm	560 mm	2 mm
Embedded	870 mm	560 mm	2 mm

POLE AND COLUMN PROTECTORS



Material

Mild steel tube.

Surface Treatment

Fully hot-dipped galvanised (after welding).

Available Finishing Treatment

Anti-UV powder coating.

TYPE	LENGTH	WIDTH	HEIGHT
Surface mounted	600 mm	600 mm	500 mm
Embedded	600 mm	600 mm	680 mm



FRENCH-OWNED COMPANY
WITH MANUFACTURING OPERATIONS IN CHINA

THANK YOU FOR YOUR INTEREST IN OUR PRODUCTS!

For more products and details, please visit our website:

<https://sinoconcept.com>



PRODUCTION & OPERATIONS CENTRE:

27 Ping Xiang Road, Shibe District,
Shui Xiang Yuan,
Building 6, Unit 3, Door 102
266011 Qingdao, China

Phone number: 0086 532 8561 1600

HEADQUARTERS:

The Cloud, RM 102 , 1/F,
111 Tung Chau Street
Tai Kok Tsui
999077 Hong Kong, China

CONTACT US

contact@sinoconcept.com